

EECS 562  
Homework 8

1. (Concept: SSB and its spectrum) Let  $x_{bb}(t) = 4\cos(2\pi 400t) + 3\cos(2\pi 450t) + 2.5\cos(2\pi 500t)$ . This signal is input to an SSB modulator with  $f_c = 5000\text{Hz}$  that uses the upper sideband.
- Plot the RF Spectrum of the SSB signal.
  - What is the required RF Bandwidth?
  - A coherent detector is required to recover  $m(t)$  from the RF signal. TRUE or FALSE
  - Mathematically show how the message signal is recovered.
  - Draw the block diagram for a receiver for this SSB signal.

2. (Concept: VSB and Pilot tones) Watch “8VSB, From Transport Stream to RF Signal” [https://www.youtube.com/watch?v=ZlAjfA-hU\\_8](https://www.youtube.com/watch?v=ZlAjfA-hU_8)
- What does the 8 refer to in 8VSB?
  - How is most of the lower sideband removed?
  - 8VSB uses a synchronous receiver, TRUE or FALSE.
  - Mathematically explain how shifting the signal by  $1.25\text{ V}$  generates the pilot signal.

3. (Concept: VSB modulation and demodulation) In this problem the information signal is  $x_{bb}(t) = 1 + \cos(2\pi 500t)$ . Let the input to the VSB shaping filter given below be  $10(1 + \cos(2\pi 500t))\cos(2\pi 10000t)$ , here  $f_c = 10\text{kHz}$ . Let  $y_{RF}(t)$  be signal at the output of the VSB shaping filter as shown below. The VSB receiver is also given below.

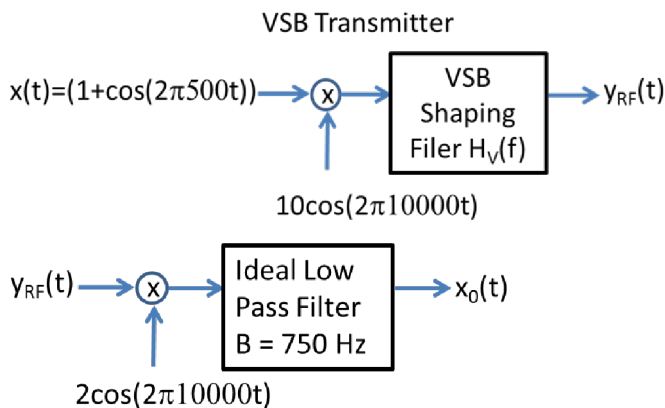
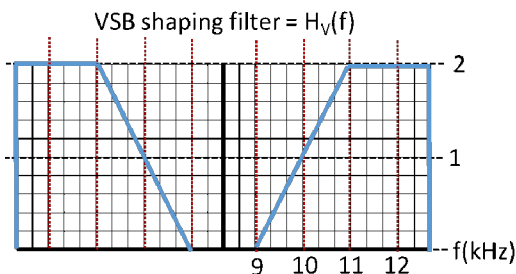

- Sketch the spectrum of  $y_{RF}(t)$ , i.e., the signal at the output of the VSB shaping filter.
- Find the output signal,  $x_o(t)$ , of the receiver.